

Data Sheet

Cryogenic Ultra-Low Noise Amplifier

Description

Ultra-low noise amplifiers are necessary for satellite missions where link margins are critical, for example for Deep Space Missions. The use of cryogenically cooled LNAs can provide improved ground station G/T at a fraction of the cost of increasing the antenna diameter.

Callisto has developed cryogenic low noise amplifiers in S-, X- and Ka-bands for the European Space Agency ground station network. Our designs use HEMT microwave devices, which are well suited for cryogenic operation. The LNA systems use a 2-stage Helium closed cycle refrigerators, which maintains the HEMT amplifier at a temperature of 15 Kelvin inside a vacuum Dewar. The refrigerator is designed for continuous operation with service intervals of more than one year.

Key Features

- Ultra low Noise Performance
- Filtering for TX protection
- S-Band through Ka-Band frequencies
- Single or multi channel/bands models
- Using Callisto's patented technology for vacuum and insulation performance
- Can restart without vacuum pump after a power outage.
- Reduced Maintenance Down Time

Cryo-LNA Specifications

Parameter	Specifications		
Frequency Band	S-Band (2.2-2.3GHz)	X-Band (8.4-8.5GHz)	Ka-Band (31.8-32.3GHz)
Noise Temperature	10K	11K	30K
Gain	> 55dB		
Input VSWR	> 1.4:1		
Base temperature	15K		
Cooldown Time	5hrs		
Warmup Time	2hrs		
Service Interval	13 000hrs		

- Other frequency ranges are available – please contact us for further information.

Ancillary Items

The system is supplied with:

- Helium Compressor and associated flexible gas lines
- PSU Drawer

Callisto's Ultra Cryogenic LNA



Typical installation site:
ESA 35m Deep Space Antenna

The specifications provided in this data sheet are preliminary and intended as a guide only. Callisto reserves the right to modify specifications without notice.

Maintenance Aspects of cryogenic LNAs

An improved maintenance concept is implemented on new cryogenic LNAs. This concept uses a sleeve system which enables the User to replace the refrigerator without opening the sealed enclosure.

The main advantage of this concept is to drastically reduce the **down-time** of the operational system (typically from 36 hours to 12 hours) and to avoid the need of having a specialist cryogenic technician on-site for services or repairs. The sleeve design means that first level maintenance actions can be carried out by the End User's own maintenance staff after a Callisto training course. The replaced refrigerator unit is simply shipped back to the factory for service or repair.



Sleeve Concept & Typical Dimensions

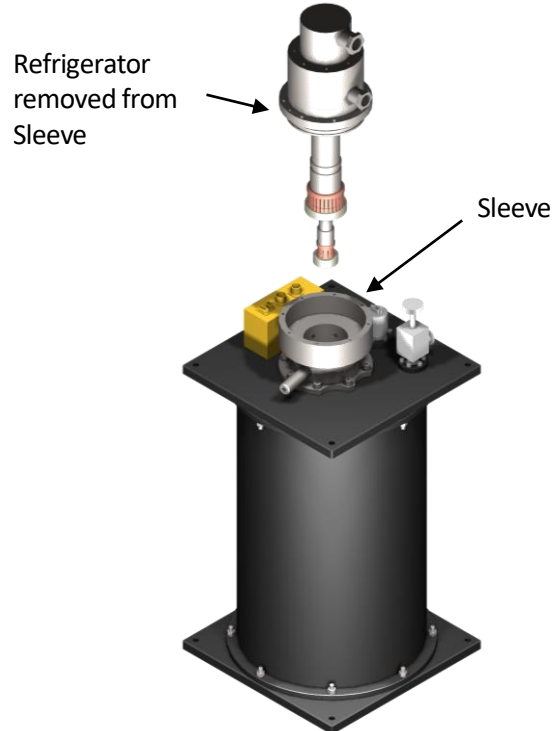
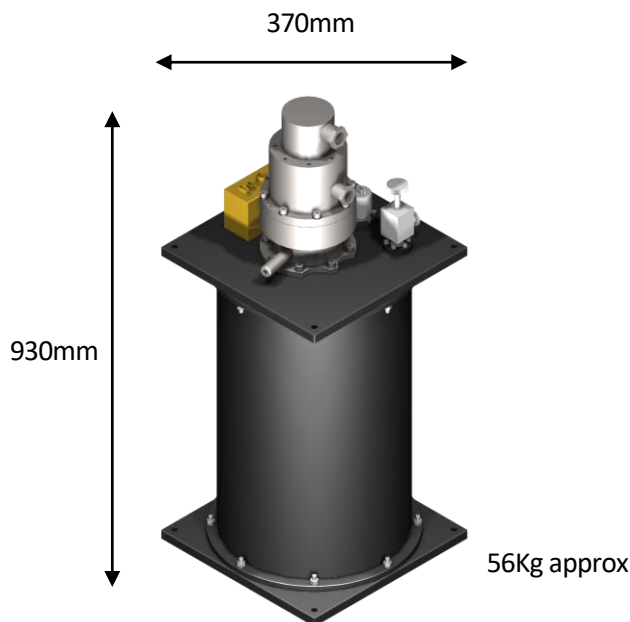

Options

A number of options can be proposed for the LNA systems including:

- PC based automatic monitoring system
- Supply of a vacuum pump
- Built-in test equipment for noise measurement
- Input/output switching redundant configuration
- Operations and maintenance training course
- Operations and maintenance training DVD

Down-time for Standard & Callisto LNA

